



**Meter Box
Commercial
IP43 Kiosk
750 x 500 x 300
Surface**

STOCK CODE: 222167

Suitable for electrical and commercial installations. Complies with the international standard for empty enclosures as applied to low-voltage switchgear and control gear assemblies (IEC 62208:2011).

KEY FEATURES

- Electromagnetic compatibility, ideal for protecting internal electronic communication.
- Suitable for low-voltage switchgear and control gear assemblies, meters, compressors, etc.
- Will not corrode, weather resistant with an IP43 rating.
- High impact resistance up to 20 Kilojoules (IK10).
- Double insulation and electrically non-conductive (1000V).
- Triple lock system supported by non-corrosive vertical bars.
- Door hinges on right, 180° opening.
- Easily cleaned and can be painted.

SPECIFICATIONS

- Constructed from Glass Reinforced Plastic (GRP).
- Supplied with Polyester back mounting plate, hinges, lock and key.
- Supplied in light grey colour (Ral 7035).
- Suitable for use in temperatures ranging from -30°C to +120°C.
- Made from non-hygroscopic material ensuring minimum water absorption.
- Constructed from halogen-free and self-extinguishing material.
- UV protected.

DIMENSIONS

750mm high x 500mm wide x 300mm deep.
The overall height of this box is 816mm.
The opening size is 721mm x 428mm*.



Example: distribution + protection board



* Approximate dimensions.

In accordance with Tricel's normal policy of product development, these specifications are subject to change without notice.



**Meter Box
Commercial
IP43 Kiosk
750 x 500 x 300
Surface**

STOCK CODE: 222167

ASSEMBLY INSTRUCTIONS

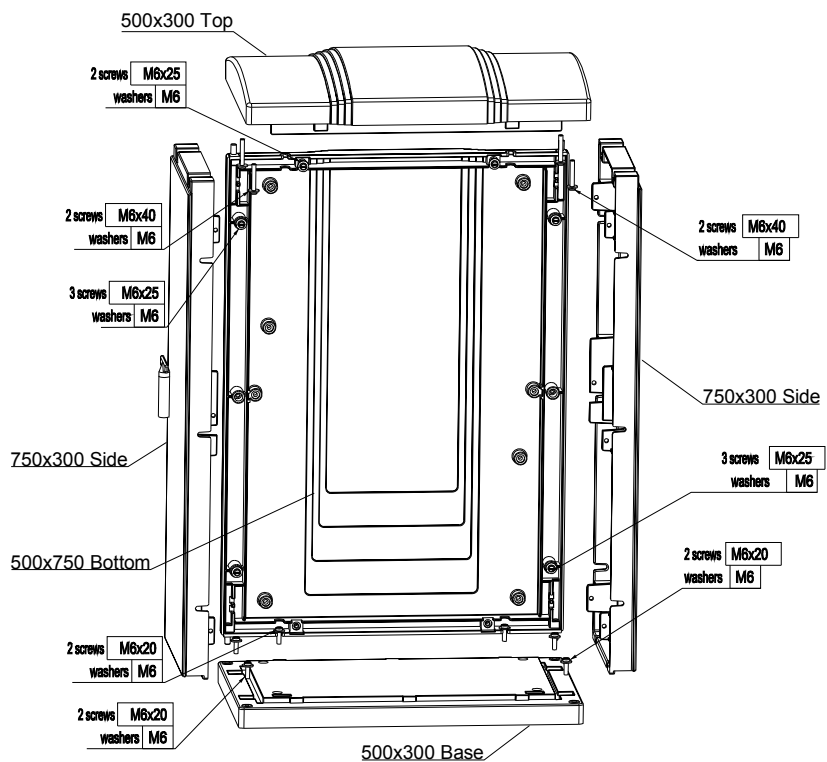

DOOR ASSEMBLY

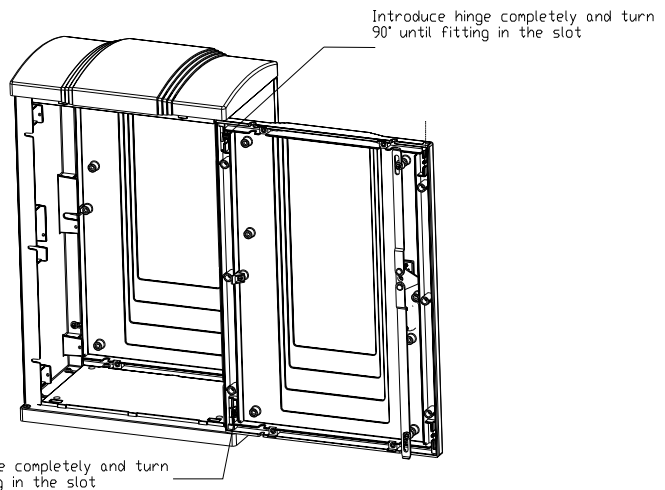

* Approximate dimensions.
In accordance with Tricel's normal policy of product development, these specifications are subject to change without notice.