

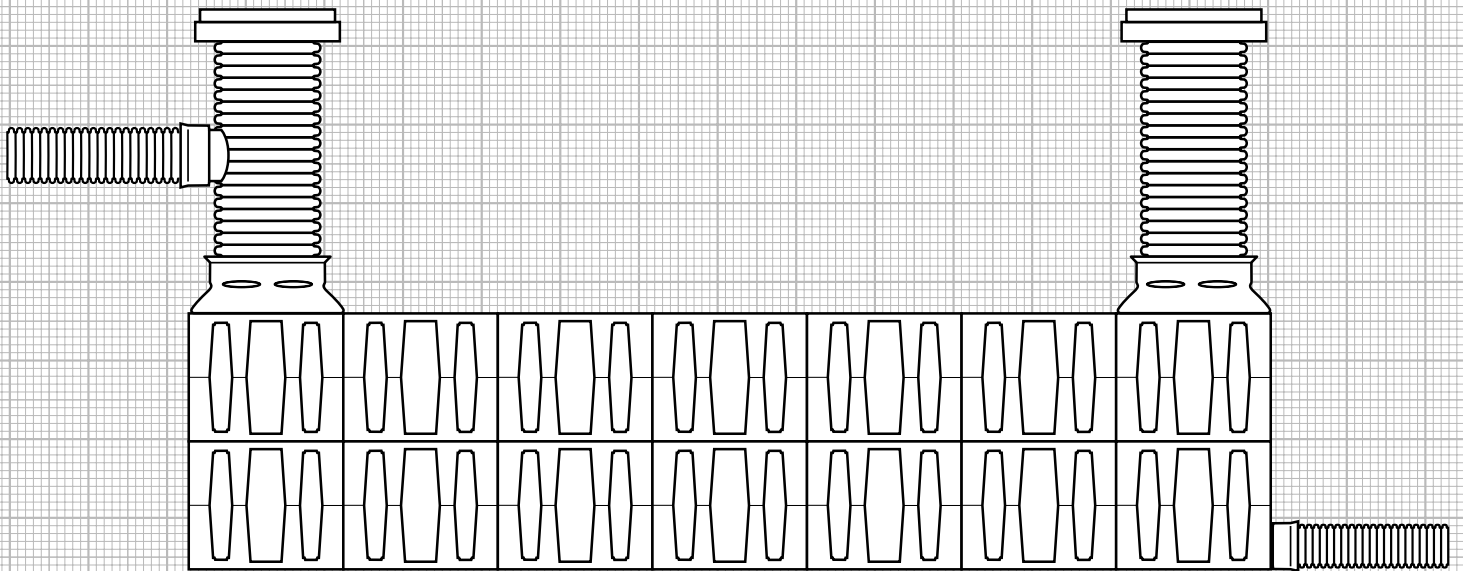

TRICEL
GENERATIONS OF INNOVATION

Installation manual

Rigofill® ST / Rigofill® ST-B



Underground storage/infiltration modules

Drainage Systems

www.tricel.ie

www.tricel.co.uk

Rigofill ST – system

Rigofill ST

■ Installation depth up to **6 m**

■ Complies with EN 17152-1

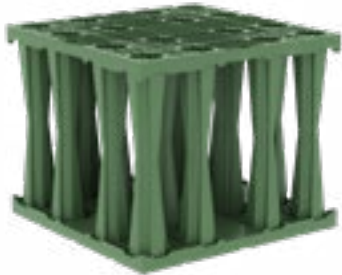

■ SLW 60/HGV 60 



Rigofill ST-B

■ Installation depth up to **4 m**

■ Complies with EN 17152-1



■ SLW 60/HGV 60 



NB

In what follows, an illustrative explanation of the Rigoill system will be given by means of the green module.

All properties and advantages also apply to the Rigofill ST-B system. The systems have been optimised for different installation situations.



In the following, please be sure to pay attention to this sign.

Statements marked with this sign apply to both Rigofill ST and Rigofill ST-B.

Table of contents

1 Rigo fill® ST - system	2
2 Rigo fill® ST - system and system components	4
3 Rigo fill® ST – storage / infiltration module	6
3.1 Transport and storage	6
3.2 Separating pallets	6
3.3 Excavating pit and creating bearing	7
3.4 Laying geotextile	7
3.5 Installation	8
4 Quadro®Control ST – shaft elements	11
4.1 Delivery	11
4.2 Shaft variants	11
4.3 Installation of shaft elements	12
4.4 Temporary construction site covers	14
4.5 Shaft covers	14
5 Final installation steps	15
5.1 Installing sidewall grids	15
5.2 Cutting openings in sidewall grids	16
5.3 Inserting adapters DN 315 / DN 400 / DN 500	16
5.4 Creating geotextile wrapping	17
5.5 Lateral backfilling	17
5.6 Creating cover SLW 60/HGV 60	18
5.7 Creating cover SLW 60/HGV 60	19
5.8 Use of construction vehicles during installation	20
6 Waterproof systems	20
7 Contact and service	21
8 Safety instructions	23

NB

Please read this installation manual carefully and follow our instructions.

This installation manual applies to

- the temperate climate zone
- infiltration systems and watertight storage systems with Nerofill ST above the maximum groundwater level (e.g. according to ATV-A 138)

The relevant safety

provisions of the building

industry apply.

2 Rigofill® ST - system and system components

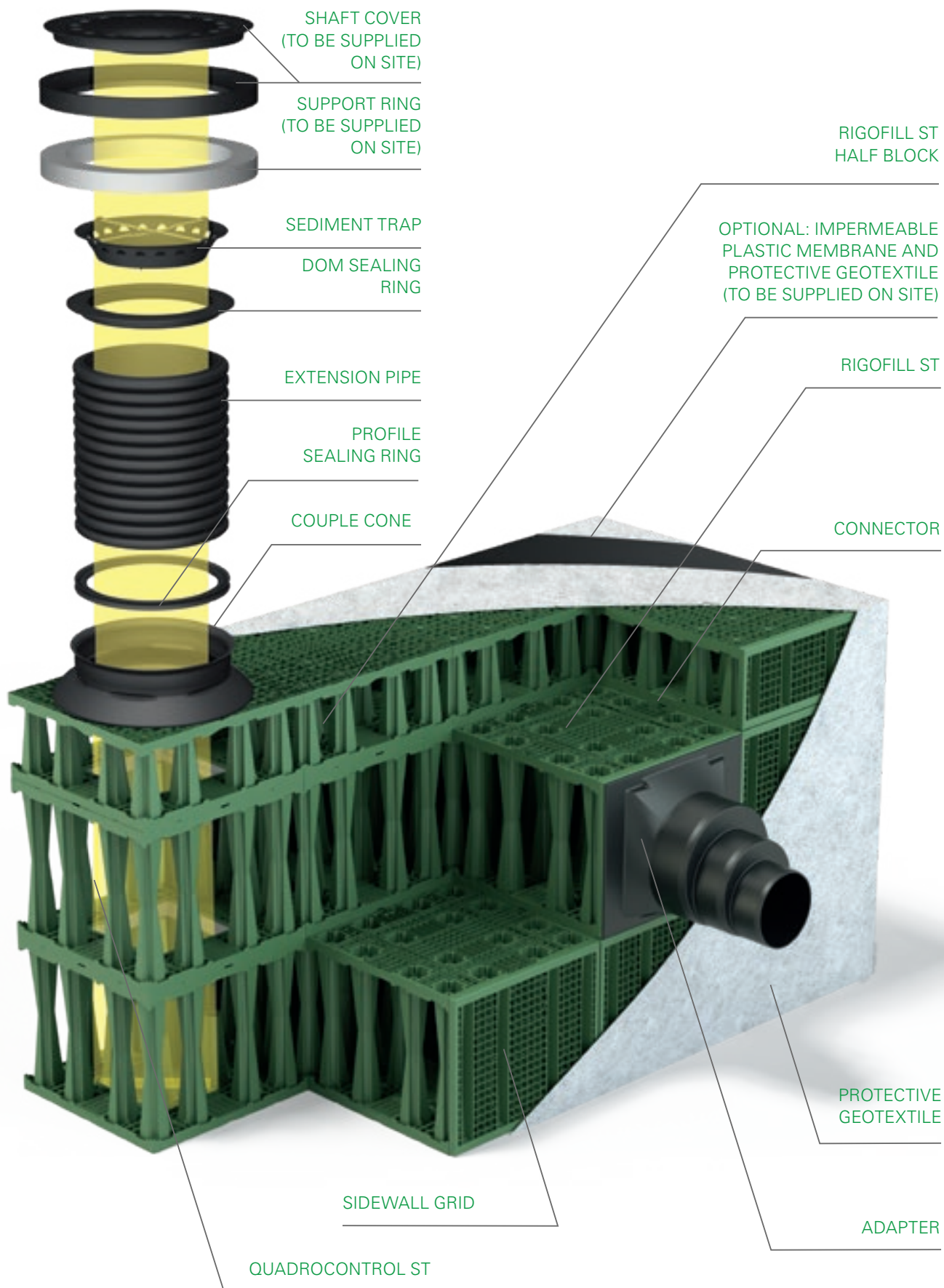

Rigofill®ST

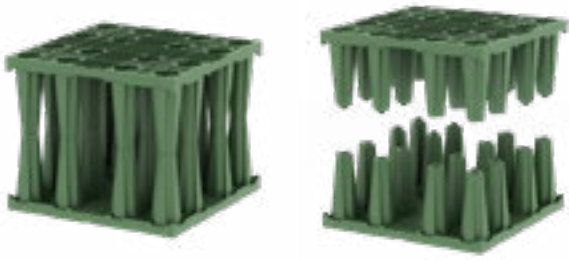

Rigofill® ST half block

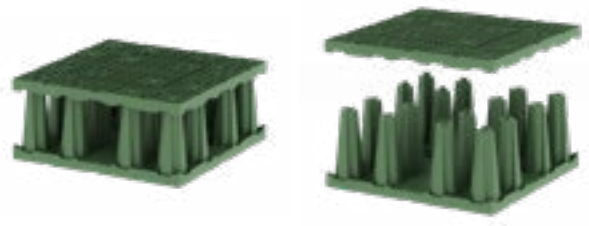

Quadro® Control ST shaft

Example: 2-layer shaft



Quadro® Control ST shaft – half layers

Multiple-layer shafts – half layers on top

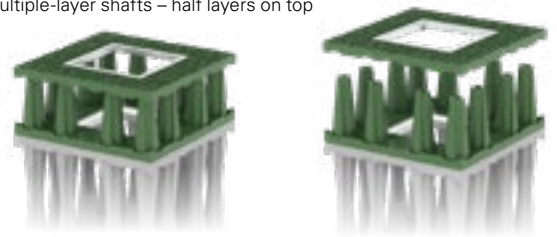

QuadroControl ST – 1/2-layer



Rigofill® ST with supporting grid

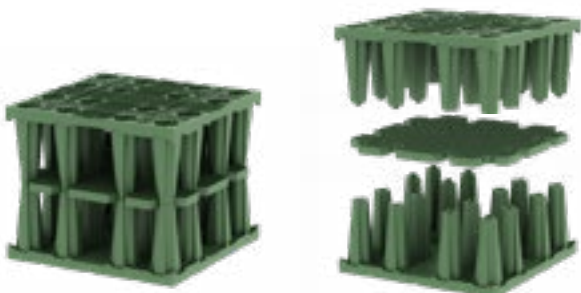

Quadro® Control ST with supporting grid



Couple cone



Sidewall grid

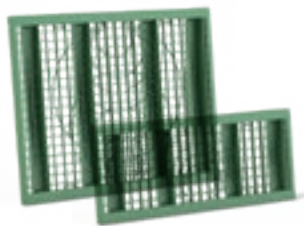

Adapter



Connector





3 Rigofill® ST – storage / infiltration module

3.1 Transport and storage



Rigofill ST modules are delivered stacked on pallets (1.60 m x 0.80 m). A pallet contains 68 half elements for 34 modules. When leaving the factory, two pallets are typically stacked on top of each other. Sidewall grids, supporting grids and roof slabs (required for half blocks only) are packed on separate pallets.

The components of the QuadroControl ST shaft are delivered pre-assembled on separate pallets. These pallets are marked correspondingly. Preferably unload the pallets using forklifts or other lifting tools. The lifting tools must have the technical equipment required for lifting gear operation.



Rigofill ST can be stored outdoors. Storage time outside should, however, not exceed **one year**. Protect the material from direct sunlight (e.g. store in the shade or cover with bright-coloured, light-tight foil).

Check the components for defects before installation. The impact strength of the material decreases in sub-zero temperatures. The relevant safety provisions of the building industry apply. **Damaged modules must NOT be installed!**

CAUTION

Solid and level ground is required for storage at the construction site. Avoid dropping, dumping and hitting the Rigofill ST modules against each other!

3.2 Separating pallets



We recommend using hoisting slings to separate both stacked pallets.

We recommend that you separate the pallets before removing the half elements.



3.3 Excavating pit and creating bearing



Excavate the pit according to design specifications. During excavation work, the walls of the pit must be sloped or constructed such that they pose no danger to the workers due to downsiding masses. Additionally, national regulations must be observed. Measures must be taken to ensure that the excavation pit is free from water during the entire execution time. This concerns especially the construction of watertight systems to avoid any upwards floating of the systems during the construction period.



In order to install the ST modules, a horizontal, level and stable bearing is essential. To this end, create a levelling layer of approx. 10 cm, preferably made of crushed stones (e.g. 2/5 mm), gravel or sand, above the bottom of the excavation pit. Compact and smooth this layer to achieve a level surface. The degree of compaction D_{pr} should be larger than or equal to 97 %, and,

depending on the requirements above the system, E_{v2} should be larger than or equal to 45 MN/m² or CBR should be larger than or equal to 12 % at the top edge of the bearing. If the soil has been included in the infiltration calculation, the permeability of the compacted layer must at least correspond to the permeability (k_f value) of the backfill soil (soil groups GE, GW, SE, SW, SI, according to DIN 18196, are usually suited for this).

The quality of the bedding is decisive for the quality of the installation and strongly affects both bearing and setting properties of the storage/infiltration systems, particularly in case of multiple-layer designs and higher loads (soil and traffic loads).

3.4 Laying geotextile



Wrap the entire storage/infiltration system in RigoFlor geotextile. Before starting to lay the modules, spread out the geotextile on the planum. The geotextile must have sufficient lateral excess length in order to eventually wrap up the entire system.

ATTENTION

Ensure that the geotextile surface is completely closed leaving no gaps even during backfilling! Edges should overlap at least 50 cm.

Important characteristics of the geotextile

- Thickness ≥ 2 mm
- Puncture resistance 2.0 kN
- Geotextile class 3
- Characteristic opening width 0.08 mm
- k_f value (at 20 kPa): 6×10^{-2} m/s
- Water permeability acc. to EN ISO 11058: 80 l/sm²
- Mass per unit area 200 g/m²
- Resistance: Anticipated resistance of up to 50 years in all natural soil types with $4 \leq \text{pH} \leq 9$ and soil temperature of ≤ 25 °C (B.4.2.2, EN ISO 13438)



3.5 Installation

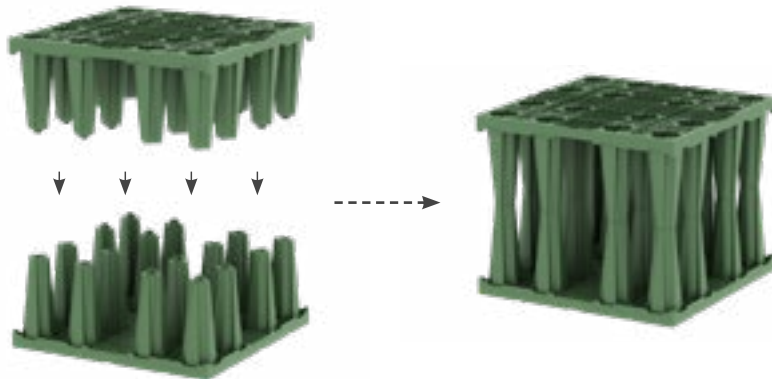

Full block installation

Each Rigofill ST module consists of two half elements. Slight hand pressure is enough to create a connection of high tensile strength.

The modules can be pre-assembled both inside and outside the excavation pit.

The pre-assembled modules must be arranged according to planning specifications.

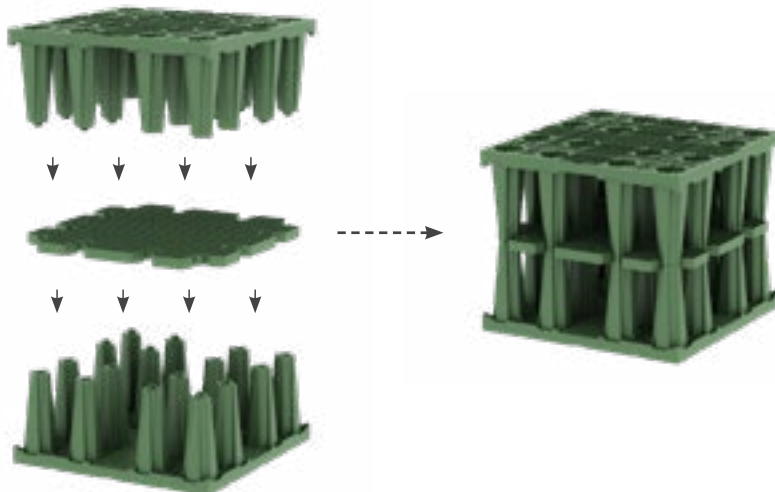

Full block installation with integrated supporting grid

If the full block has an integrated supporting grid, this must be placed between the two half elements beforehand.

The modules can be pre-assembled both inside and outside the excavation pit.

The pre-assembled modules must be arranged according to planning specifications.

ATTENTION

Half blocks must be installed with the roof slab located on top.

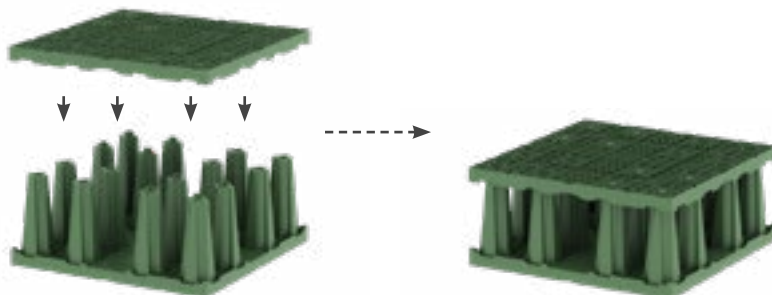

Half block installation

Each Rigofill ST half block consists of one half element and one roof slab put together. Slight hand pressure is enough to create a connection of high tensile strength. The modules can be pre-assembled both inside and outside the excavation pit.

For a 0.5-layer system, the pre-assembled modules must be arranged on the planum according to planning specifications. **For multiple-layer systems, the half blocks must be arranged in the top layer.**



3.5.1 Pre-assembly outside the excavation pit



3.5.2 Pre-assembly inside the excavation pit



Assembly inside the excavation pit

CAUTION

Installation at sub-zero temperatures requires greater care (impact stability, please refer to the section on transport and storage). Modules are slippery when wet or frosty!



3.5.3 Connectors

Use connectors to secure modules in position during installation. Install connectors according to the diagram below.

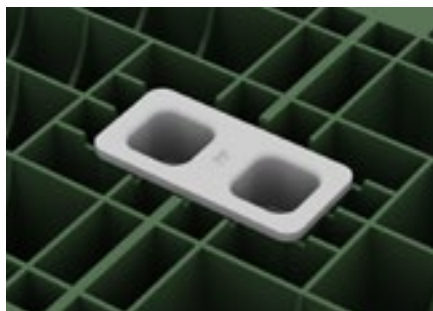

Single-layer connector for installation in the roof slab of half-/single-layer systems

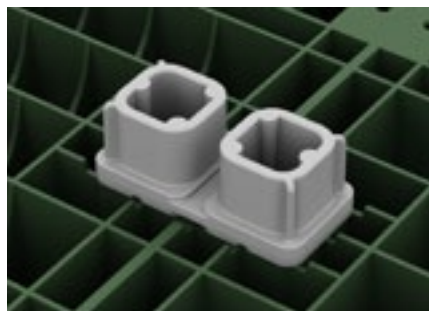

Multiple-layer connector for installation in multiple-layer systems between different layers, for connecting layers with each other

Determination of requirements

Connector	Application	Requirement	
Single-layer	for half-layer/single-layer installation	requirement for single-row installation	1 pc(s). per module
		requirement for multiple-row installation	2 pc(s). per module
Multiple-layer	for multiple-layer installation, between the layers	requirement for 2-layer installation	1 pc(s). per module
		requirement for 3-layer installation	1.3 pc(s). per module

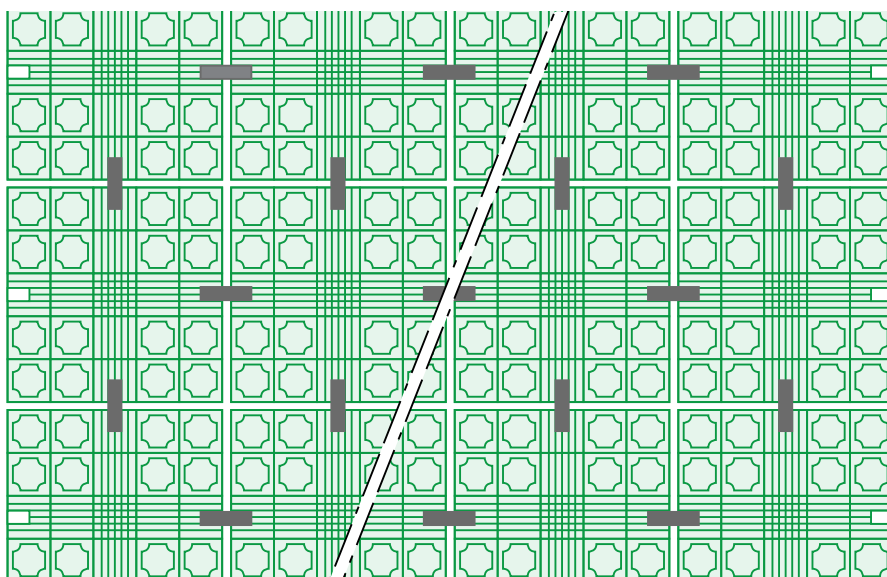



4 Quadro®Control ST – shaft elements

4.1 Delivery

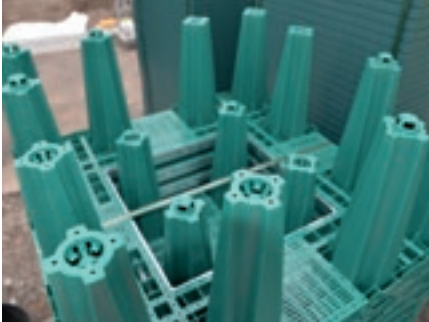

The components of the QuadroControl ST shaft are delivered to the site pre-assembled and packed on a pallet.

4.2 Shaft variants

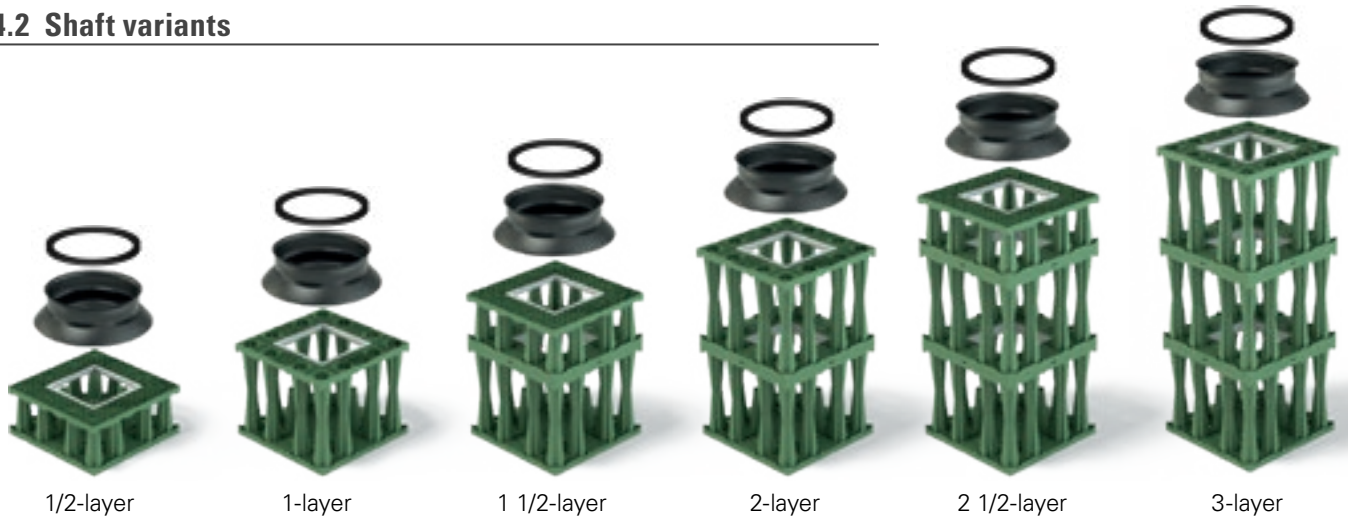

Product		Cone	Profile sealing ring for extension pipe	Shaft half element	Shaft roof slab with frame	Half element
		pc(s).	pc(s).	pc(s).	pc(s).	pc(s).
QuadroControl ST 1/2	51504005	1	1		1	1
QuadroControl ST 1	51504010	1	1	1		1
QuadroControl ST 1 1/2	51504015	1	1	2	1	1
QuadroControl ST 2	51504020	1	1	3		1
QuadroControl ST 2 1/2	51504025	1	1	4	1	1
QuadroControl ST 3	51504030	1	1	5		1
QuadroControl ST 3 1/2	51504035	1	1	6	1	1
QuadroControl ST 4	51504040	1	1	7		1
QuadroControl ST-B 1/2	51504205	1	1		1	1
QuadroControl ST-B 1	51504210	1	1	1		1
QuadroControl ST-B 1 1/2	51504215	1	1	2	1	1
QuadroControl ST-B 2	51504220	1	1	3		1
QuadroControl ST-B 2 1/2	51504225	1	1	4	1	1
QuadroControl ST-B 3	51504230	1	1	5		1



4.3 Installation of shaft elements



The basis of a QuadroControl ST shaft – no matter the design – is always a closed half element, as used in a Rigofill ST module. In the following, special shaft elements with recess and metal frame are positioned.

The shaft cone always forms the upper end of each shaft.
The cone will later form the transition from the shaft to the extension pipe.



Shaft design

The normal shaft design consists of shaft half elements with recess and a metal frame (except the closed half element forming the base).



The shaft half element can be rotated 180° like a normal half element – when put together, two half elements form a full layer.

Shaft design half-layer

Use the shaft roof slab with frame for half-layer shafts.



ATTENTION

Half-shaft on top (open at the bottom)



ATTENTION

QuadroControl 1/2-layer



Shaft design with supporting grid

Proper installation is mandatory for systems with supporting grids due to reasons of stability. For QuadroControl ST shafts with an integrated supporting grid, this must be placed between the half elements beforehand.



Supporting grid

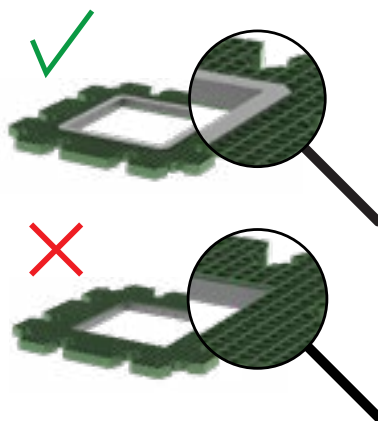
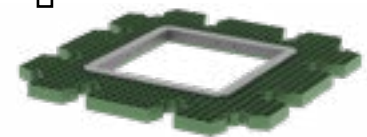

NB

During installation, make sure that the metal frame integrated in the supporting grid faces upwards.



The shaft is constructed layer by layer and it grows as construction of the unit progresses. The installation of the bottom layer of the QuadroControl ST shaft always starts with connecting the half element and the shaft half element.



Install the shaft bottom in the intended position in the layout. Please ensure that the opening with the metal frame faces upwards. Use connectors to connect to the adjacent Regofill ST modules.



Additional complete layers

Each of these layers is made of two shaft half elements combined. Place the shaft components onto the already existing shaft bottom using multiple-layer connectors.

How to place cones



Regardless of the number of layers, the couple cones provide the transition to the extension pipes. The couple cones are preferably to be put on the shaft openings only after the upper system layer has been completed. Before installing the couple cones, the entire storage/infiltration system incl. shafts must be covered with the wrapping geotextile. The geotextile must be cut out at the square openings.

Installation of extension pipes

The extension pipes are inserted into the cone coupling by means of sealing rings included in the delivery (please use lubricant). Prior to that, profile sealing rings must be placed into the **first**

corrugation trough of the extension pipes. Make sure that the extension pipes are installed upright and do not shift during compaction.

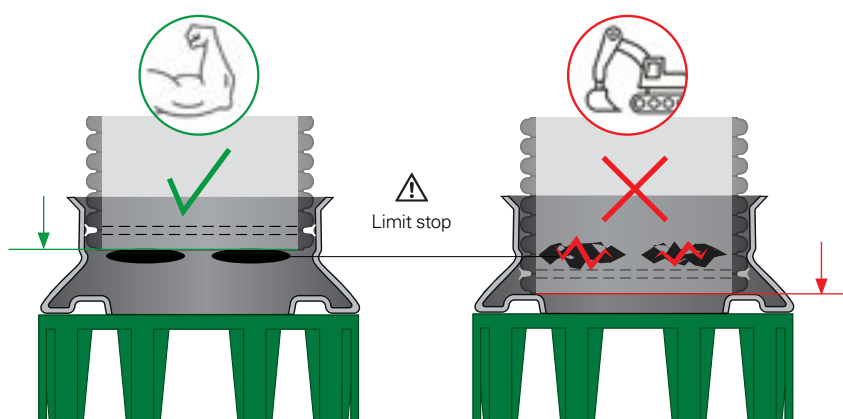

ATTENTION

Mount the sealing ring onto the first corrugation trough. Make sure that the extension pipe is only inserted up to the limit stop (use lubricant).



4.4 Temporary construction site covers

Extension pipes are delivered with temporary construction site covers. They are used to prevent backfill or other dirt from entering the shafts during installation. The construction site cover is not accessible and may not be trafficked! Do not remove temporary construction site covers before installing permanent shaft covers.



Purpose of temporary construction site covers when backfilling



Temporary construction site cover for extension pipes

4.5 Shaft covers

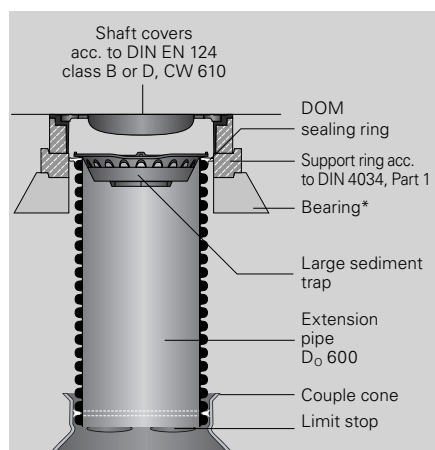

Shaft cover on the shaft (e.g. inspection shaft)
* to be supplied on site

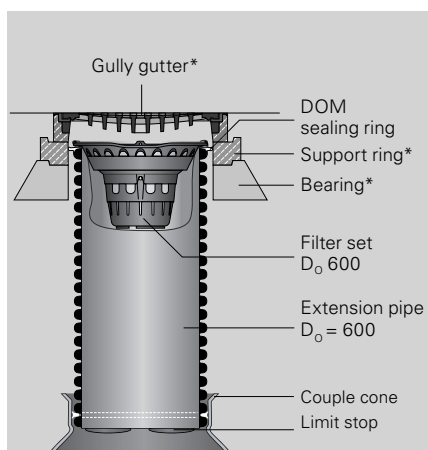

Gully gutter on the shaft (e.g. swale emergency overflow)
* to be supplied on site

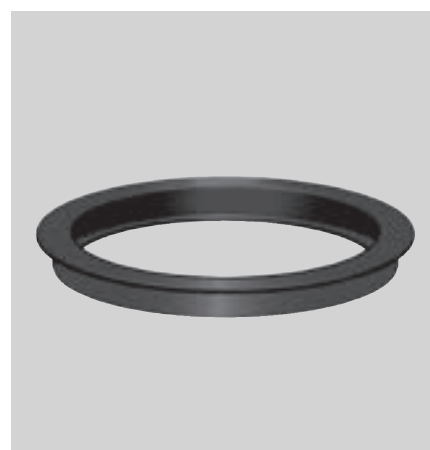

DOM sealing ring

After installing the cover (see next Section), shaft covers can be placed. Cut the extension pipe D_o 600 such that it reaches the support ring. The gap between the support ring and the shaft cover must be sealed using a DOM sealing ring. Mount the sealing ring onto the last corrugation of the extension pipe. Place a sediment trap D_o 600 on the extension pipe. If, according to the design specifications, the shaft must feature a gully gutter, place the filter set D_o 600 on the extension pipe.

Shaft covers or gully gutters and concrete support rings are not included in the scope of delivery and must be supplied on site. Shaft covers must be carried out and installed according to planning specifications. The inside diameter must be at least 610 mm. Shaft covers must be suitable for the expected traffic loads. If national guidelines such as EN 124 are applicable, they must be observed.

Put a support ring $h = 100$ mm on an appropriate bearing under the shaft cover/gully gutter. Create the bearing from compacted bearing layer material or in-situ concrete C 16/20.

Avoid interlocking of the bearing with the corrugations of the extension pipe (use casing aid!). Vertical loads may only be transferred to the load-bearing underground.

5 Final installation steps



5.1 Installing sidewall grids

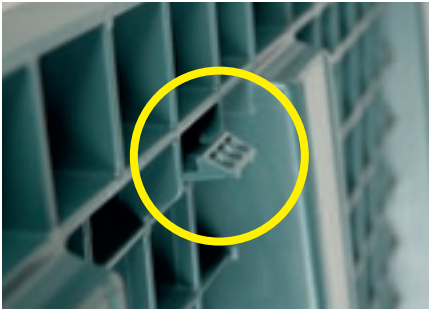

Use sidewall grids to cover tunnel ends of the storage/infiltration system. Place the sidewall grid in the centre. Pressing the sidewall grid is enough to connect the module tight using four locking pins.



Depending on on-site requirements, the installation of the sidewall grids can already take place outside the excavation pit.



ATTENTION

If there is enough space, the installation of all sidewall grids can alternatively be carried out after the installation of modules has been completed.

Similar application with sidewall grid/half block.

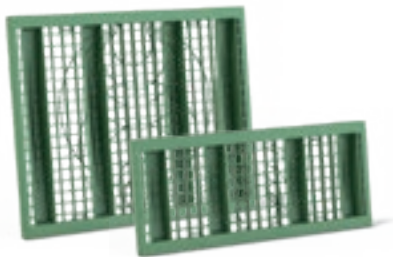

NB

In storage/infiltration designs with inside corners, shortened sidewall grids are used at one side.

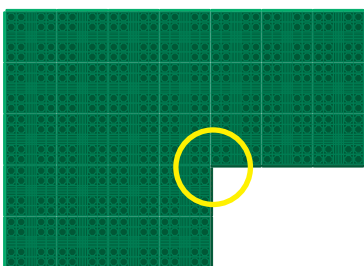

Special quality: inside corner

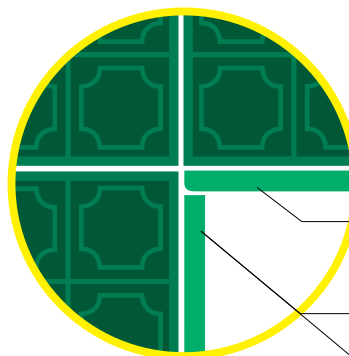

Rigofill ST-B sidewall grid

Rigofill ST-B sidewall Cat. grid, short

Rigofill ST-B half block sidewall grid, short

Rigofill ST sidewall grid

Rigofill ST sidewall grid, short Cat.

Rigofill ST half block sidewall grid,

I011



5.2 Cutting openings in sidewall grids

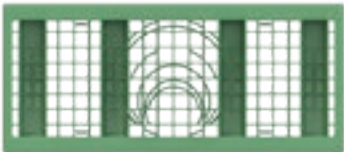
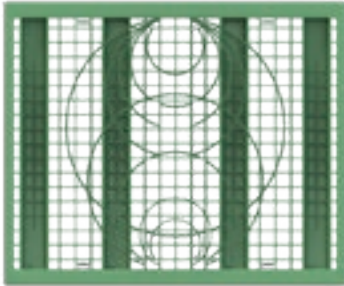

Module layers	Connection height
1/2-layer	0.04 m
1-layer	0.04 m
1 1/2-layer	0.70 m
2-layer	0.70 m
2 1/2-layer	1.36 m
3-layer	1.36 m
3 1/2-layer	2.02 m
4-layer	2.68 m

Connection heights (independent of nominal diameter) from the swale bottom

To directly connect supply pipe and drain pipe, the sidewall grids have pre-marked circles for solid wall pipes with nominal diameters of DN/OD 110 to 500 (DN/OD 110 to 250 for sidewall grid/half block).

NB

We recommend using a jigsaw.

5.3 Inserting adapters DN 315 / DN 400 / DN 500



NB

An angular grinder is best suited for cutting. Please cut approx. 1 cm from the edge to maintain the insertion chamfer. Mount the prepared adapter to the module just like a sidewall grid and secure it using an adapter fastener.

The adapter must be cut to the nominal diameter according to planning specifications. You can establish pipe connections directly to the KG spigot using a KG coupling.

The pipe DN 315 can be connected directly. The adapter can be installed at soil level or turned by 180° at crown level.



5.4 Creating geotextile wrapping



Rigofill systems must be wrapped completely in geotextile. At the edges, sufficient overlapping shall be provided (at least 50 cm) to make sure no backfill material enters the system. Produce sand-tight pipe inlets by cross-shaped cutting of the geotextile.

ATTENTION

Ensure that the geotextile surface is completely closed leaving no gaps even during backfilling!

5.5 Lateral backfilling



CAUTION

Compacting using vibratory rollers and explosion rammers is not permissible!

Connectors secure the individual Rigofill ST modules and prevent the storage/infiltration system from shifting during backfilling. Use non-cohesive, non-frozen earthwork material with a maximum grain size of 32 mm for backfilling. Distribute the backfill material evenly and compact it in layers

of max. 30 cm using a light or medium compacting machine (area vibrator or vibratory rammer). In doing so, a compaction level D_{pr} of larger than or equal to 97 % should be achieved. The modules must NOT be damaged. National guidelines for earthworks (such as ZTV E-StB) must be adhered to.

Make sure that the geotextile overlapping is not pulled apart during backfilling and compacting and that the Rigofill ST modules are not damaged!

The permeability of the backfill must at least correspond to the permeability of the backfill soil.

5.6 Creating cover SLW 60/HGV 60

The storage/infiltration system must be covered according to design specifications. Non-cohesive, compactable graded earthwork material with a maximum grain size of 32 mm should be used for the cover, which is a mandatory requirement under traffic areas! **Frozen soil is not permissible!** Additionally, national guidelines for earthworks (such as ZTV E-StB) apply here as well.

Stability analysis

Storage/infiltration systems are subsoil structures and must have sufficient load-carrying capacity against impacting soil and traffic loads. The stability must be proven according to Eurocode, taking into account partial safety factors and/or limiting factors. With conventional installation parameters*, depths of cover of D_c of max. 4 m and soil depths of D_s of

max. 6 m are possible for infiltration systems. A project-specific stability analysis can be prepared by Tricel. Under traffic areas, a minimum cover D_c of 80 cm must be observed.

* HGV 60; specific weight of soil 19 kN/m³; friction angle 30°; $\kappa = 0.3$; mean soil temperature 23 °C

Standard installation under a traffic area

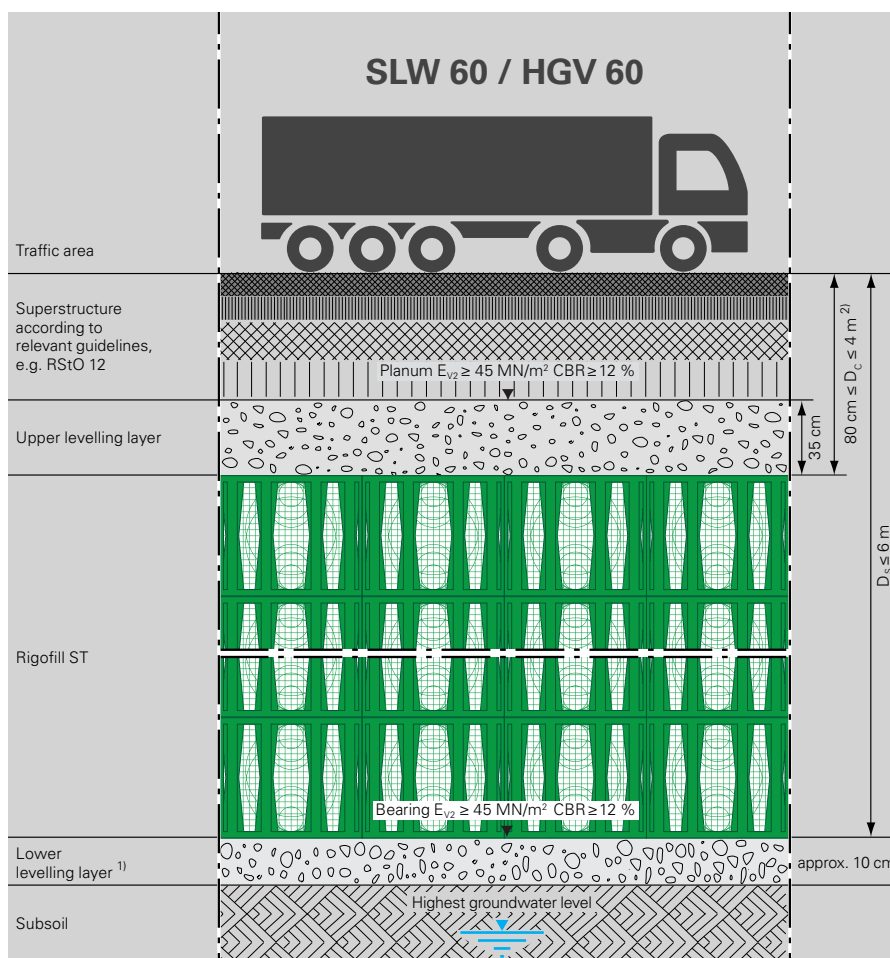

¹⁾ At least the same permeability (k_f) as the subsoil for infiltration systems

²⁾ Lower cover upon request

Rigofill ST

SLW 60 / HGV 60

ATTENTION

Note for groundwater over structure soil: Rigofill ST systems, which are used as watertight storage systems with impermeable membranes, have been designed for application above the highest groundwater level. Use in groundwater is possible under corresponding technical conditions after consultation with Tricel. Please contact us!

National guidelines, e.g. RStO 12, must always be observed for installation under traffic areas. To build the planum for the subsequent road construction, an upper levelling layer must be provided, preferably a gravel sub-base with a thickness of at least 35 cm, which depends on the required modulus of deformation. Other construction materials normally lead to greater carrier layer thicknesses.

Unless defined otherwise by national guidelines, at the surface of the cover (= planum), a uniform modulus of deformation $E_{v2} \geq 45 \text{ MN/m}^2$ or $\text{CBR} \geq 12 \%$ must be achieved. Other required moduli of deformation lead to greater or smaller thicknesses of the upper levelling layer.

Soil layers must always be provided and compacted in layers of no more than 30 cm. The compaction level D_{pr} should be larger than or equal to 97 %.

Carry out compacting using light or medium area vibrators only!

CAUTION

Compacting using vibratory rollers and explosion rammers is not permissible!

5.7 Creating cover SLW 60/HGV 60

The storage/infiltration system must be covered according to design specifications. Non-cohesive, compactable graded earthwork material with a maximum grain size of 32 mm should be used for cover, which is a mandatory requirement under traffic areas! **Frozen soil is not permissible!** Additionally, national guidelines for earthworks (such as ZTV E-StB) apply here as well.

Stability analysis

Storage/infiltration systems are subsoil structures and must have sufficient load-carrying capacity against impacting soil and traffic loads. The stability must be proven according to Eurocode, taking into account partial safety factors and/or limiting factors. With conventional installation parameters*, depths of cover of D_c of max. 2.5 m and soil depths of D_s

of max. 2,30 m are possible for infiltration systems. A project-specific stability analysis can be prepared by Tricel. Under traffic areas, a minimum cover D_c of 80 cm must be observed.

* HGV 60; specific weight of soil 19 kN/m³; friction angle 30°; $K = 0.3$; mean soil temperature 23 °C

Standard installation under a traffic area

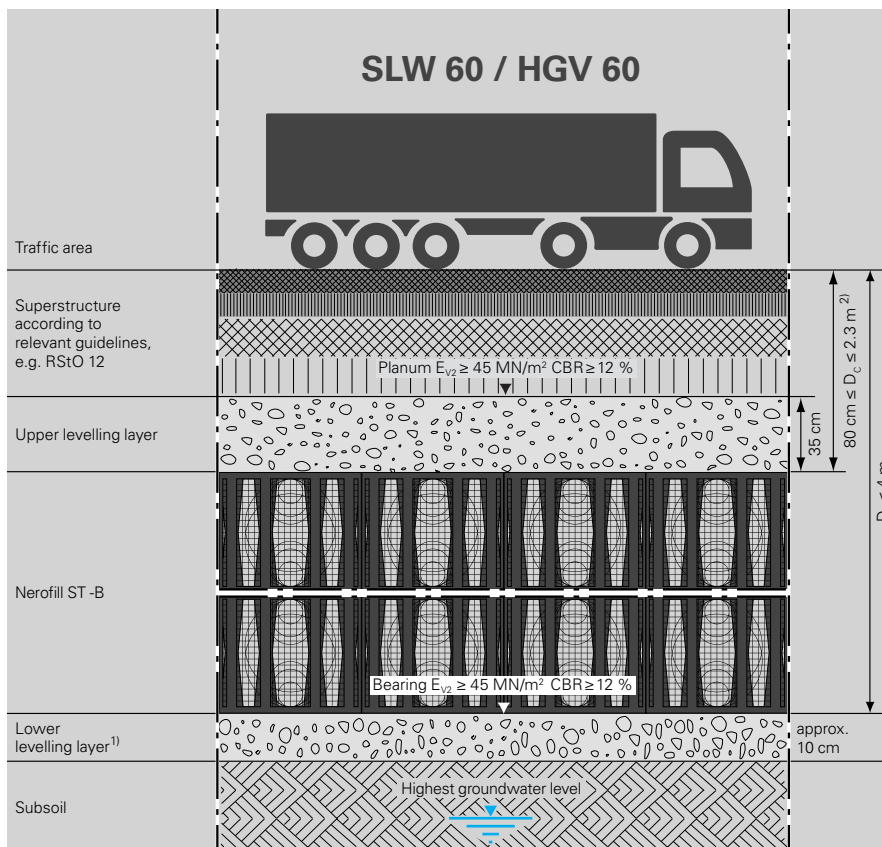

¹⁾ At least the same permeability (k_f) as the subsoil for infiltration systems

²⁾ Lower cover upon request

Nerofill ST-B

SLW 60 / HGV 60

ATTENTION

Note for groundwater over structure soil: Rigofill ST-B systems, which are used as watertight storage systems with impermeable membranes, have been designed for application above the highest groundwater level. Use in groundwater is possible under corresponding technical conditions after consultation with Tricel. Please contact us!

National guidelines, e.g. RStO 12, must always be observed for installation under traffic areas. To build the planum for the subsequent road construction, an upper levelling layer must be provided, preferably a gravel sub-base with a thickness of at least 35 cm, which depends on the required modulus of deformation. Other construction materials normally lead to greater carrier layer thicknesses.

Unless defined otherwise by national guidelines, at the surface of the cover (= planum), a uniform modulus of deformation $E_{v2} \geq 45 \text{ MN/m}^2$ or CBR $\geq 12 \%$ must be achieved. Other required moduli of deformation lead to greater or smaller thicknesses of the upper levelling layer.

Soil layers must always be provided and compacted in layers of no more than 30 cm. The compaction level D_{pr} should be larger than or equal to 97 %.

Carry out compacting using light or medium area vibrators only!

CAUTION

Compacting using vibratory rollers and explosion rammers is not permissible!



5.8 Use of construction vehicles during installation



Use of vehicles when applying the first cover layer:

The first cover layer can be applied, for example, using a wheel loader or a front-type mobile excavator. For a wheel loader or mobile excavator with a maximum total weight of 15 tons (chain, 4 wheels, twin-tyres), a compacted cover of at least 30 cm must be placed over the storage/infiltration system. Possible formation of ruts must be taken into account! Avoid steering manoeuvres at this construction stage.

Use of construction vehicles

Driving over the cover with heavy construction vehicles with a wheel load of up to 50 kN (e.g. HGV 30) is possible if the thickness of the compacted cover is not less than 60 cm. Possible formation of ruts must be taken into account!

When dumping the earthwork material, the wheel load of 50 kN must not be exceeded; if necessary, load distribution plates must be used.

CAUTION

It is not permissible to drive construction vehicles directly on the modules!

6 Waterproof systems



Modular reservoir construction for many applications

When using Rigofill ST for stormwater storage, the system can be wrapped in impermeable plastic foil. Please observe the manufacturer's specifications when installing the impermeable plastic foil.

In addition to the static verification, uplift verification is required in case of groundwater. Dewatering measures are to be checked and, if necessary, provided during construction in order to prevent upwards floating of watertight systems if these are not yet sufficiently covered.

Applications

- Stormwater retention
- Stormwater harvesting (tank)
- Fire water storage
- Combined applications

Follow the steps described in this manual to install the modules.

Install and weld the impermeable membrane and execute the impermeability test of individual weld seams according to the instructions of the manufacturer/installer.





7 Contact and service

Tricel Killarney, Ballyspillane Industrial Estate, Killarney, Co Kerry, Ireland

Tel: +353 (0) 64 663 2421 | Email: sales@tricel.ie | www.tricel.ie

Tricel Weston, Winterstoke Road, Weston-super-Mare, BS24 9AN, UK

Tel: +44 (0) 1934 422 311 | Email: environment@tricel.co.uk | www.tricel.co.uk

8 Safety instructions

ATTENTION

Staff responsible for installation, assembly, operation, maintenance and repair must have appropriate qualifications required for this kind of work. The builder is responsible for organising in detail authority, responsibility and supervision of staff.

The operational safety of the system components supplied is only guaranteed in case of proper installation and correct use. Technical threshold values must not be exceeded.

Observe the accident prevention regulations and relevant standards and directives for installation, fitting, operation, maintenance, and repair of systems, pipes, and shafts!

These are inter alia (in extracts):

- Accident prevention regulations
 - Construction work BGV C22 (*Bauarbeiten BGV C22*)
 - Technical wastewater systems GUV-V C5 (*Abwassertechnische Anlagen GUV-V C5*)
- Safety regulations for working in enclosed spaces of technical wastewater systems GUV-R 126 (*Sicherheitsregeln für Arbeiten in umschlossenen Räumen von abwassertechnischen Anlagen GUV-R 126*)
- Handling biological working materials in technical wastewater systems GUV-R 145 (*Umgang mit biologischen Arbeitsstoffen in abwassertechnischen Anlagen GUV-R 145*)
- Directives for working in tanks and narrow spaces BGR 117 (*Richtlinien für Arbeiten in Behältern und engen Räumen BGR 117*)
- Standards
 - Excavations and trenches – Slopes, planking and strutting, breadths of working spaces DIN 4124 (*Baugruben und Gräben-Böschungen, Verbau, Arbeitsraumbreiten*)
 - Construction and testing of drains and sewers DIN EN 1610 (*Verlegung und Prüfung von Abwasserleitungen und -kanälen*)
- Tool for safety and health protection in technical wastewater systems

WARNING

- Hazards from gases and vapours such as risk of suffocation, risk of poisoning and risk of explosion
- Risk of falling
- Risk of drowning
- Germ pollution and wastewater with sewage
- High physical and psychological stress during work in deep, narrow and dark spaces
- And others

DANGER

Non-compliance with the operating manual may result in considerable property damage, injury or death.

CAUTION

The systems, pipes and shafts are part of an entire network.
During installation, maintenance, service and repair work, always consider the entire system.
Avoid work during rain.

Changes or modifications may only be carried out with the agreement of the manufacturer.
For safety reasons, use original spare parts and accessories approved by the manufacturer.
The use of other parts voids the liability for any consequences arising therefrom.

General information on using our products and systems:

Information about or assessments of the use and installation of our products and systems are exclusively provided on the basis of the information submitted. We do not assume any liability for damage caused by incomplete information. If the actual situation deviates from the planned situation or if a new situation occurs or if different or new installation techniques are applied, these must be agreed upon with TRICEL, since these situations or techniques may lead to different conclusions. Notwithstanding the above, the customer is solely responsible for verifying the

suitability of our products and systems for the intended purpose. In addition, we do not assume any liability or responsibility for system characteristics and system functionalities when third-party products or accessories are used in combination with TRICEL systems. We only assume liability if original TRICEL products are used. For use in other countries than Germany, country-specific standards and regulations must also be observed.

All information provided in this publication is generally up to date at the time of printing. Moreover, this publication was prepared with the greatest possible care. However, we cannot rule out printing errors or translation mistakes. Furthermore, we reserve the right to change products, specifications and other information, or changes may be necessary due to legal, material or other technical

requirements, which no longer could be considered for this publication. For this reason, we are unable to accept any liability if this is based solely on the information contained in this publication. Instrumental in connection with information about products or services is always the purchase order, the concrete product purchased and the related documentation or the information provided by our specialist staff in the specific case.

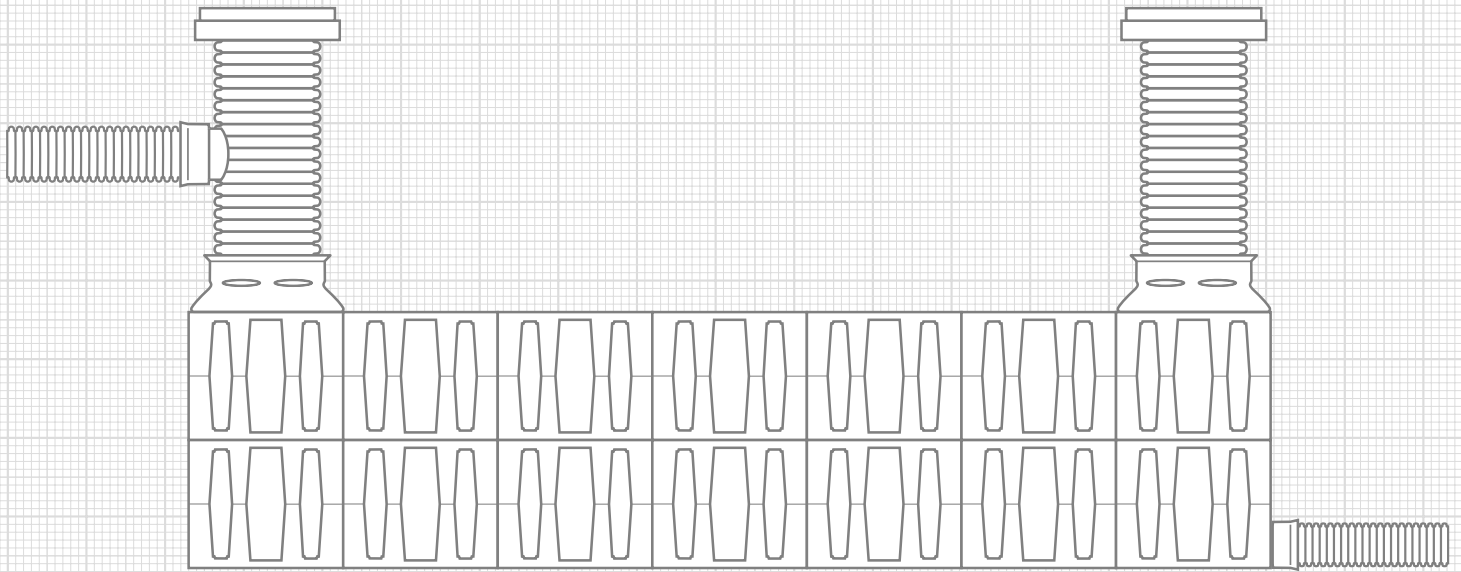

© stock.adobe.com

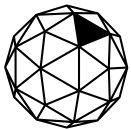

TRICEL
GENERATIONS OF INNOVATION

FRÄNKISCHE

For more information or to receive a quote, contact your Tricel's representative.

Tricel Killarney, Ballyspillane Industrial Estate, Killarney, Co Kerry, Ireland
Tel: +353 (0) 64 663 2421 | Email: sales@tricel.ie | www.tricel.ie

Tricel Weston, Winterstoke Road, Weston-super-Mare, BS24 9AN, UK
Tel: +44 (0) 1934 422 311 | Email: environment@tricel.co.uk | www.tricel.co.uk

In accordance with Tricel's normal policy of product development these specifications are subject to change without notice.

1429743/0-March2024